

# Installation Manual

ver.2.0A

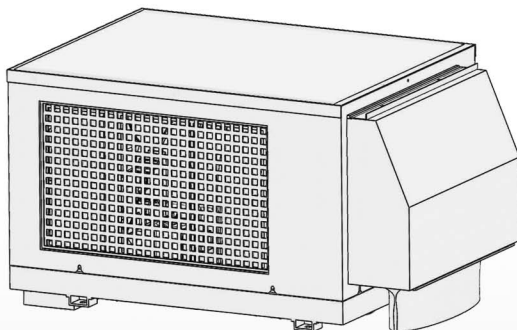

## Air-L Series

(EL070A/EL090A/EL120A/EL135A)

### CONTENTS

Name of each parts  
Before Installation  
Installation  
Electric wiring  
Check Before Driving  
Wiring Diagram

**Carrier APA.,Ltd**

Air-conditioning Practical Application Service Co.

# Name of each parts

Check the name of parts.

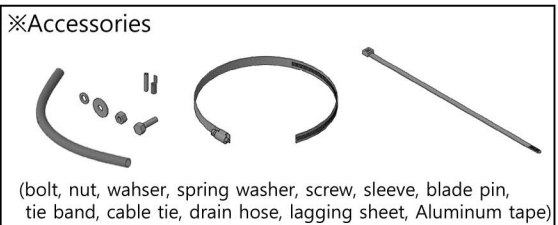
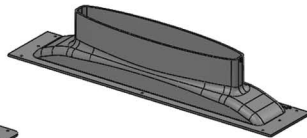
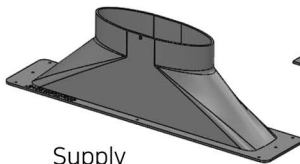
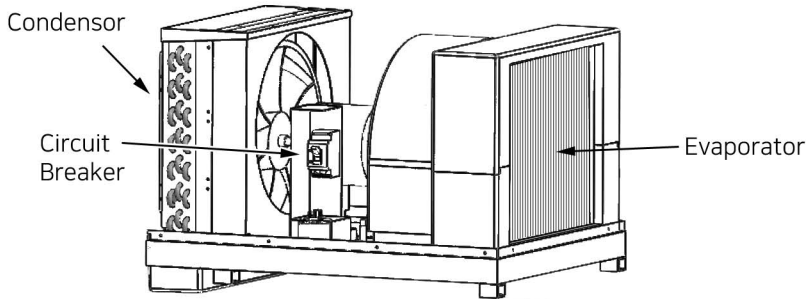
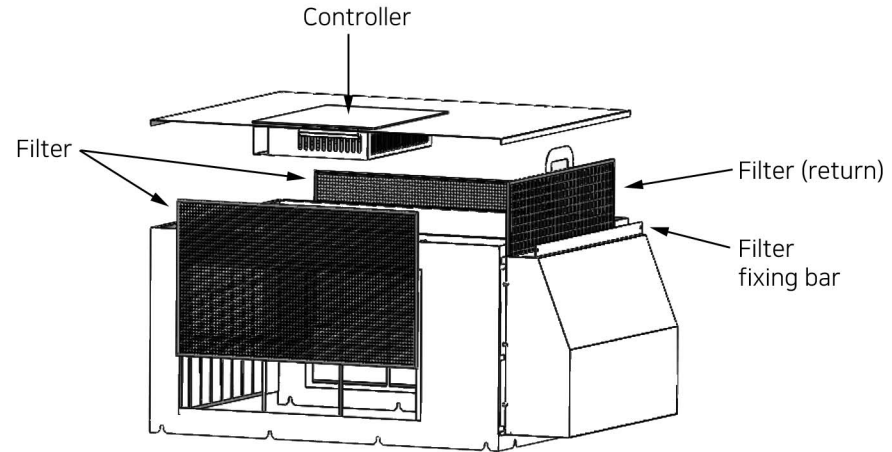

# Before Installation

Check top of the elevator.

- ▷ Check a proper space where will be installed the air-con.
- ▷ The space should be free from any distractions; safety guide or emergency exits.
- ▷ Check the air supply hole and return hole on top of the elevator.

(Hole size is recommended '370mm x 60mm')

return Scooper

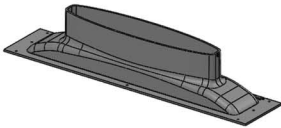

supply Scooper

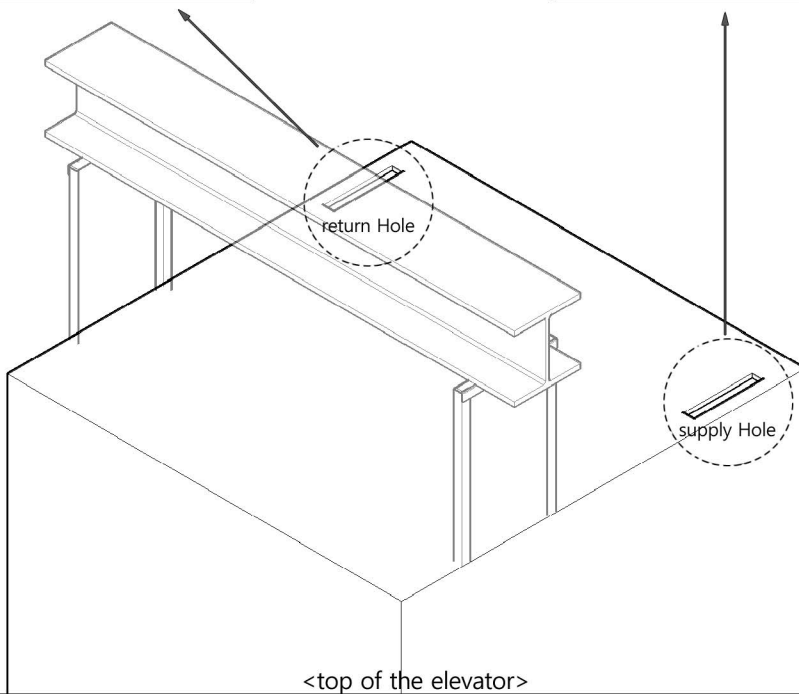
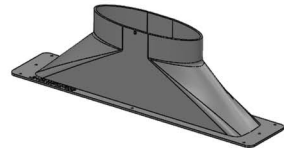

# Installation

The following step of instructions must be performed.

## 1. Proper space for installing.

▷ There is a proper space where will be installed the air-con.

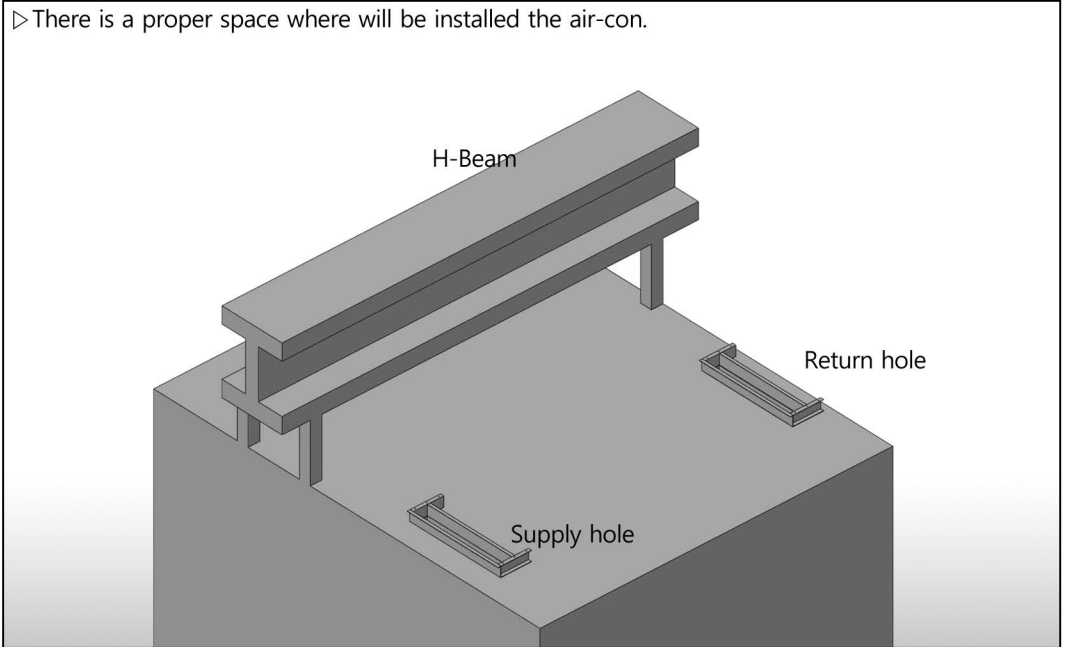

## 2. Mount the angle.

▷ The angle is mounted on H-beam by bolt(10mm bolt, nut, washer, spring washer).

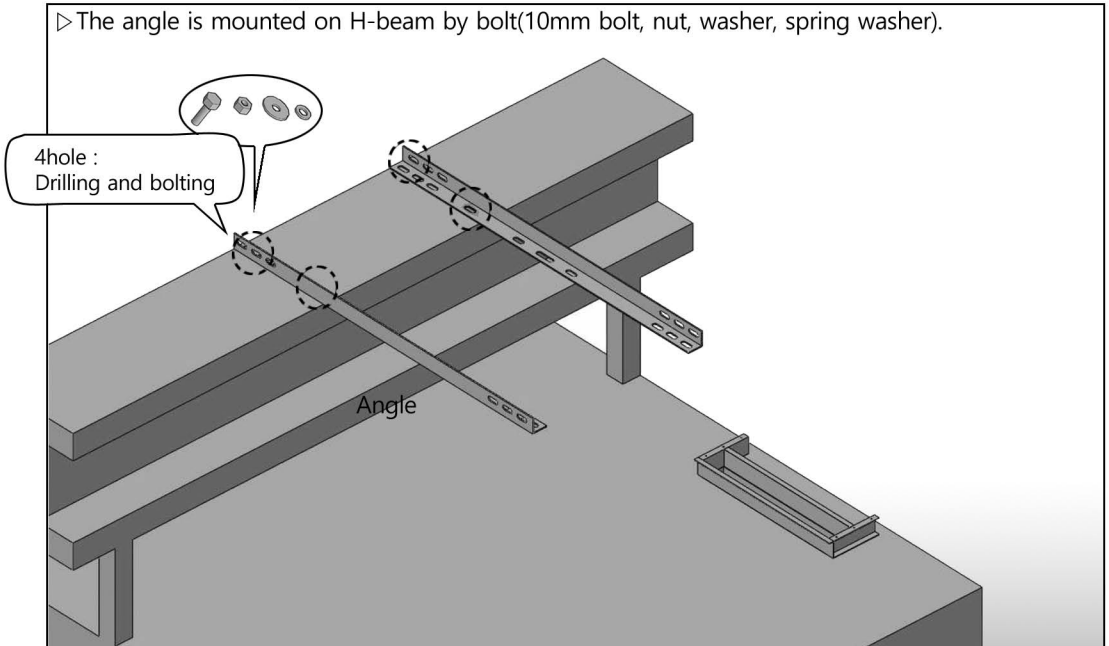

# Installation

The following step of instructions must be performed.

## 3. Mount Unit.

▷ Put unit on the angle with anti-vibrator.

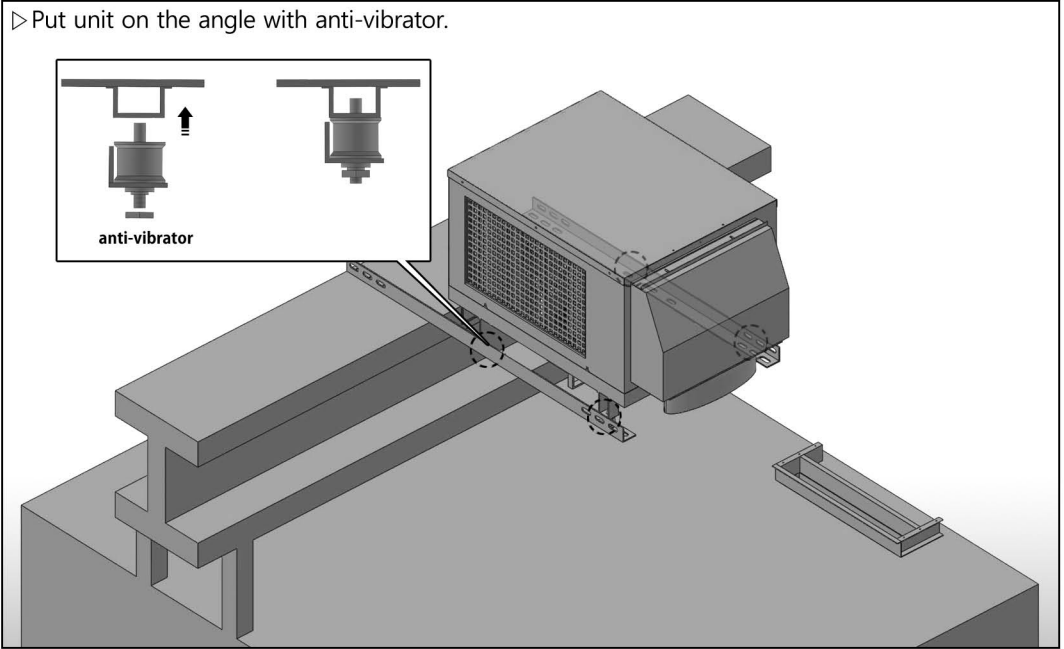

## 4. Emergency Drain hose / USB Cable

- ▷ ① Emergency Drain hose is connected with pipe of unit.
- ② Remote usb cable is connected with usb socket of controller for wireless communications.

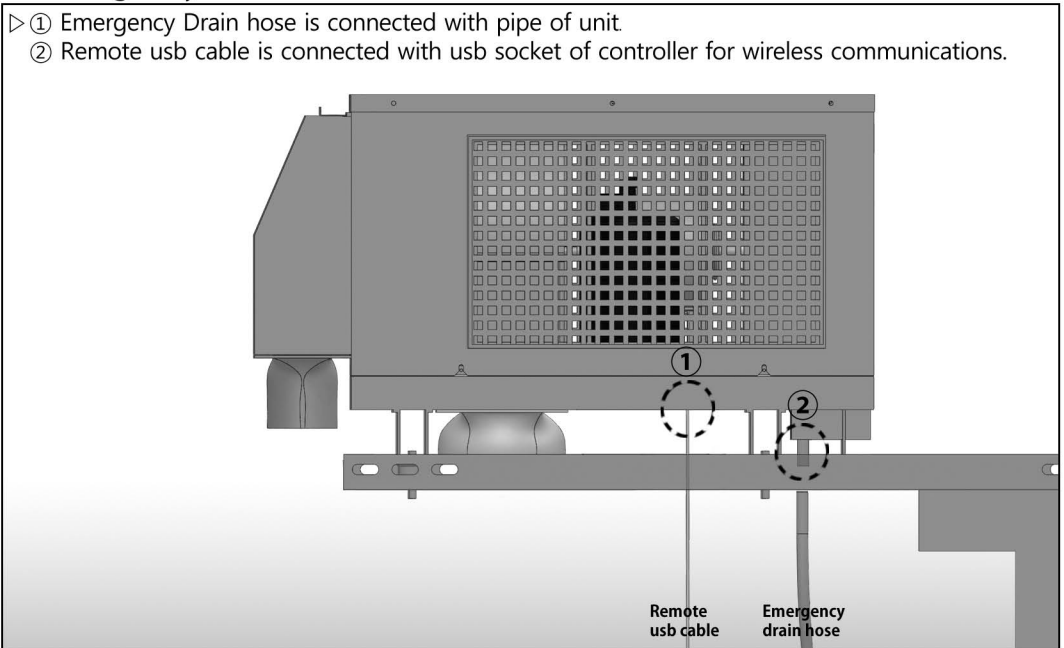

# Installation

The following step of instructions must be performed.

## 5. Emergency Drain hose / USB Cable

▷ Connect a remote cable with wireless gender.

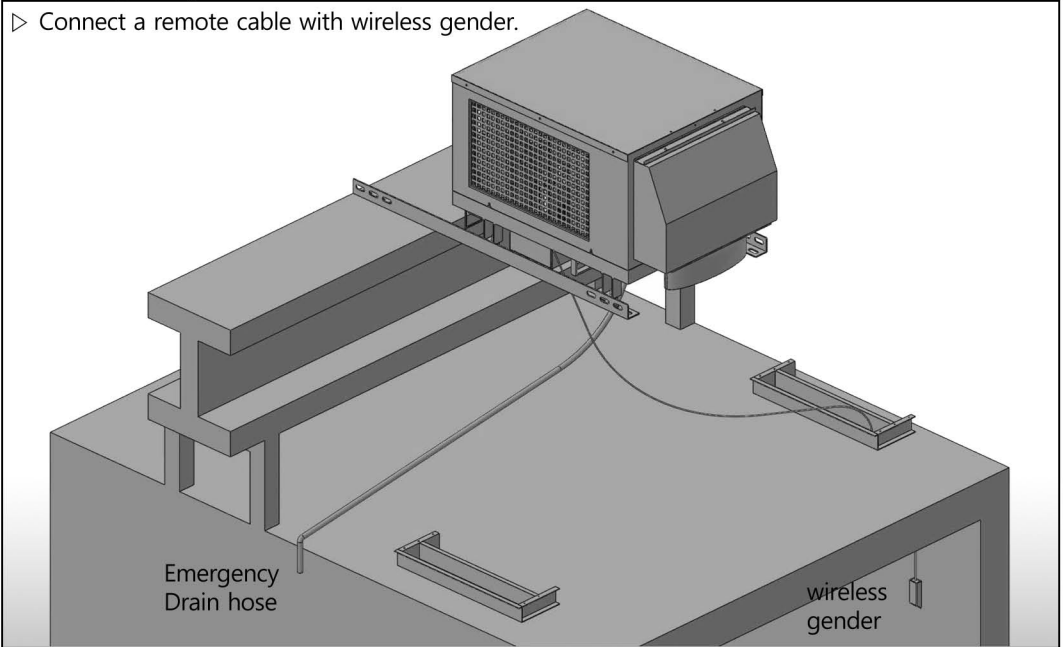

## 6. Scooper installation.

▷ The scooper is screwed to the Air-Hole.

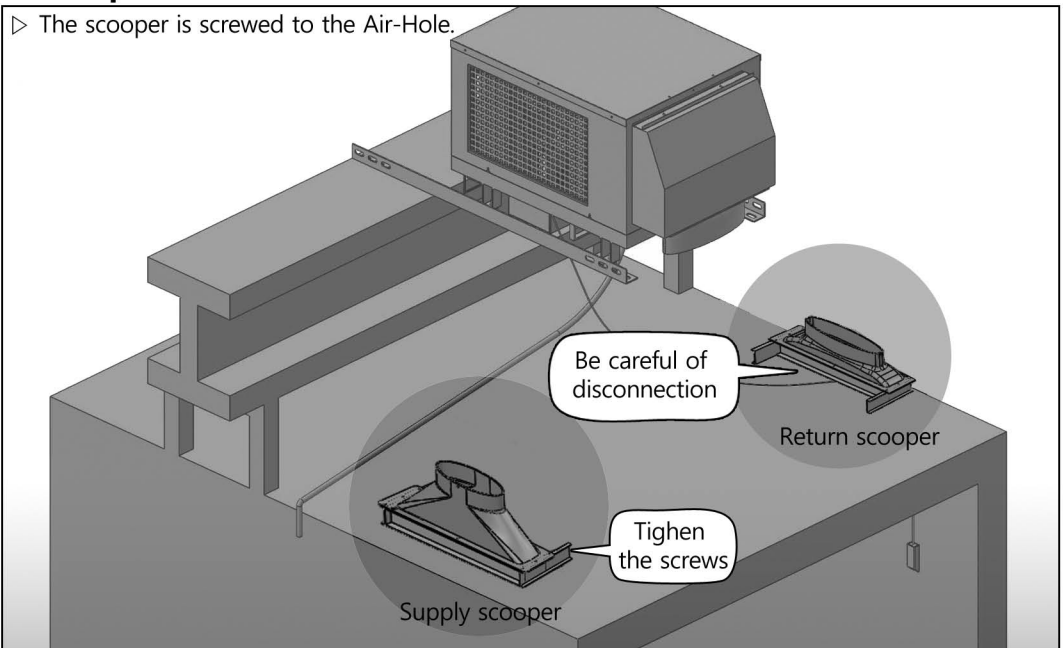

# Installation

The following step of instructions must be performed.

## 8. Flexible duct connection.

- ▷ ① 8" return duct is connected with return hole by sus band and cable tie.
- ▷ ② 6" supply duct is connected with supply hole by sus band and cable tie. And cover duct with Aluminum sheet.

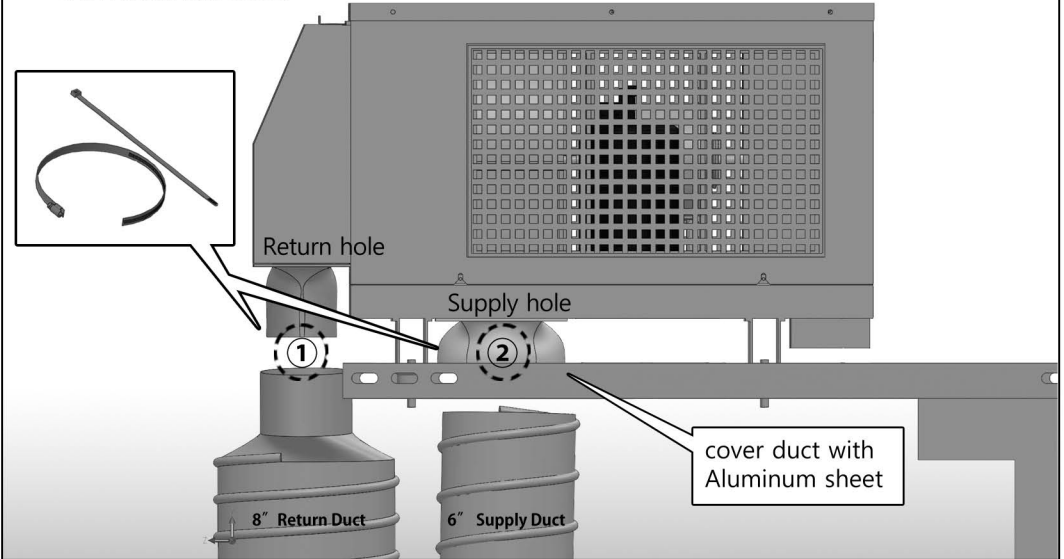

## 9. Flexible duct connection.

- ▷ Flexible duct is Connected with scoopers.
- ▷ Cut flexible duct to proper length. Length depends on installation place, usually 1m~1.5m. (too long length makes wind speed down.)

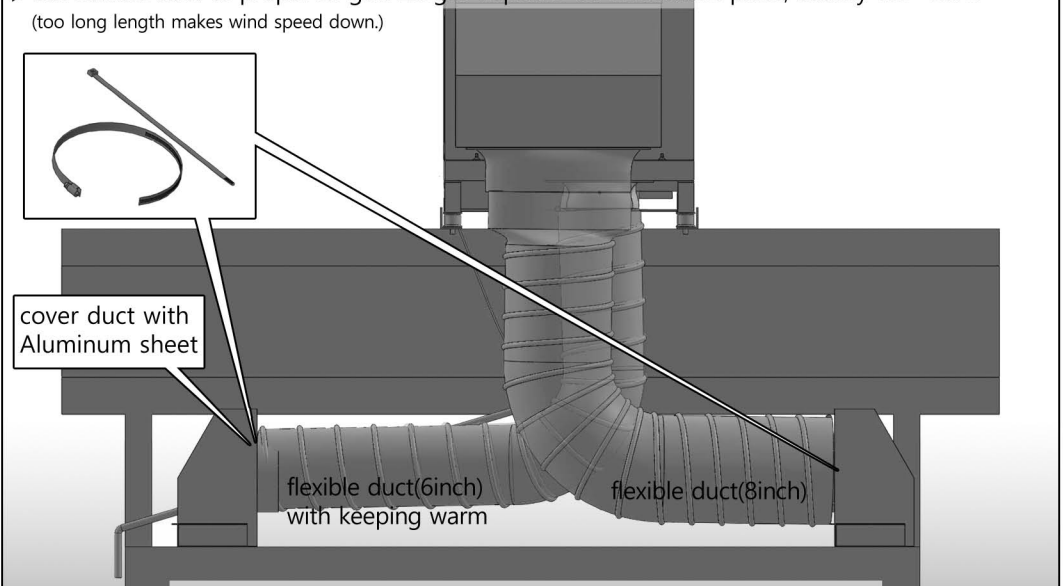

# Electrical wiring

Make sure that all power supply to the unit is disconnected before performing any work on the unit to void the possibility of shock or injury or damage to the equipment.

## Wiring - power

- ▷ Main power cable is 2 black wires. It is from circuit breaker in the unit. When connect it with Main power cable, use long sleeve and blade pin.

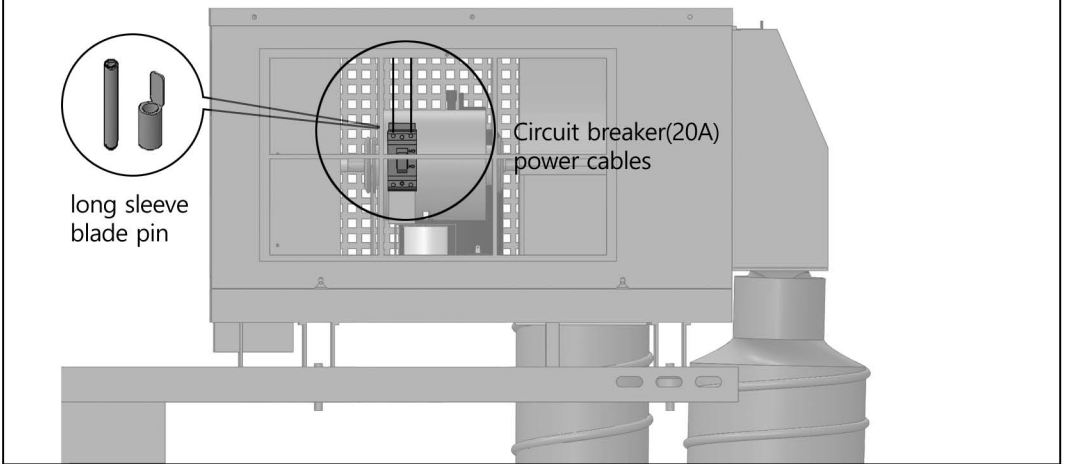

## Wireless remote connection

- ▷ It can control all of air-con function in the elevator as wireless.

