

LIFT INVERTER SERIES L1000A



L1000A
L1000A
L1000A
L1000A

For
Modernisation
and
New Installation

YASKAWA L1000A

FOR HIGH PERFORMANCE LIFT APPLICATION

Contents

- ▶ **Page 2**
Experience & Innovation
- ▶ **Page 3**
Main Features
- ▶ **Page 4**
Energy & cost efficiency
- ▶ **Page 5/6**
Simple & stress free handling
- ▶ **Page 7/8**
Safe & comfortable rides
- ▶ **Page 9**
Specifications
- ▶ **Page 10**
Connection Diagram
- ▶ **Page 11**
Terminal Functions
- ▶ **Page 12/13**
Dimensions
- ▶ **Page 14**
Options
- ▶ **Page 15**
Options
Ratings & Type Descriptions

Experience & Innovation

For more than 90 years YASKAWA has been manufacturing and supplying mechatronic products for machine building and industrial automation. Its standard products as well as tailor-made solutions are famous and have a high reputation for outstanding quality and durability.

YASKAWA has a track record also of manufacturing and supplying inverters to drive the lift industry: more than 60.000 sold lift inverter units every year.

The L1000A Inverter Series is a dedicated inverter drive for lift applications suitable for both modernisation projects and new installations.

Based on many years of experience and application oriented innovation the L1000A provides high-performance characteristics offering a set of attractive features:

- ▶ Energy and Life-Cycle-Cost efficiency
- ▶ Simple and stress-free handling
- ▶ Safe and comfortable rides

The YASKAWA L1000A uses special hardware designed for 3 million starts and more than 70.000 hrs of maintenance free operation. It provides advanced control functions to run induction and PM motor applications in geared or gearless elevator systems.

With its motor capacities ranging from 1.5 to 110 kW the L1000A is capable of driving almost any elevator. In addition, the L1000A is quickly installed and can be integrated into most control systems.



L1000A main features

- ✓ Energy & cost efficiency
- ✓ Simple & stress-free handling
- ✓ Safe & comfortable rides



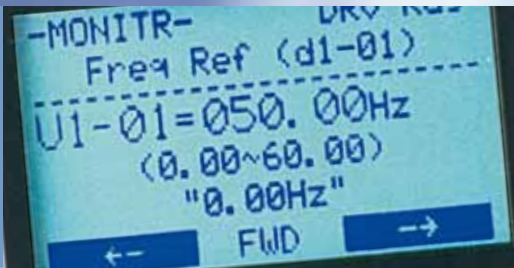

Main Features:

Energy & cost efficiency

The YASKAWA L1000A provides technical features and special design which enhance product applicability and reliability for first class efficiency.

- ▶ Designed for three million starts at 165% output current and more than 70,000 hrs of maintenance-free operation
- ▶ Service Performance Monitor
- ▶ New light load function for UPS (Uninterrupted Power Supply)
- ▶ Advanced motor & drive technology for gearless PM motor control
- ▶ Built-in braking transistor for all models up to 30 kW

Simple handling

The L1000A strictly responds to the requirements of the lift markets. It shows great system flexibility and user focus.

- ▶ Software supports all common controllers in the market
- ▶ Lift language (Hz, m/s, rpm, levelling speed, service speed, nominal speed)
- ▶ Multifunction terminal board with parameter backup function.
- ▶ Software support tool DriveWizard Plus
- ▶ Various types of Auto-Tuning for induction and gearless permanent magnet motors
- ▶ Powerful torque characteristics
- ▶ LCD operator for parameter handling as standard
- ▶ USB copy unit
- ▶ Four relay outputs for each fault and brake control.

Safe & comfortable rides

Based on years of experience in the market YASKAWA includes many functions & features to ensure the elevator works smooth and gives passengers a comfortable lift.

- ▶ Specialized lift software based on many years of experience
- ▶ Input voltage sensors for phase loss detection
- ▶ Simple and efficient brake sequence
- ▶ High levelling accuracy even in open-loop, thanks to load detection during run
- ▶ Five independent settings of S-curves to prevent jerks
- ▶ Improved torque ripple suppression
- ▶ Torque compensation at start without load sensor
- ▶ Overshoot and anti-vibration control
- ▶ De-magnetization protection for PM motor
- ▶ Rescue Operation Function
- ▶ Only one motor contactor needed in compliance with EN81-1





Energy & Cost Efficiency

Advanced motor/drive technology

High performance current vector control technology for induction and synchronous motor operation

- ▶ Single software parameter to switch between motor types
- ▶ Perfect for a wide range of lift applications

Control Modes

Synchronous motors (SPM/IPM drive): Closed Loop Vector for PM

Induction motors: V/f control, Open-Loop Vector, Closed-Loop Vector Control

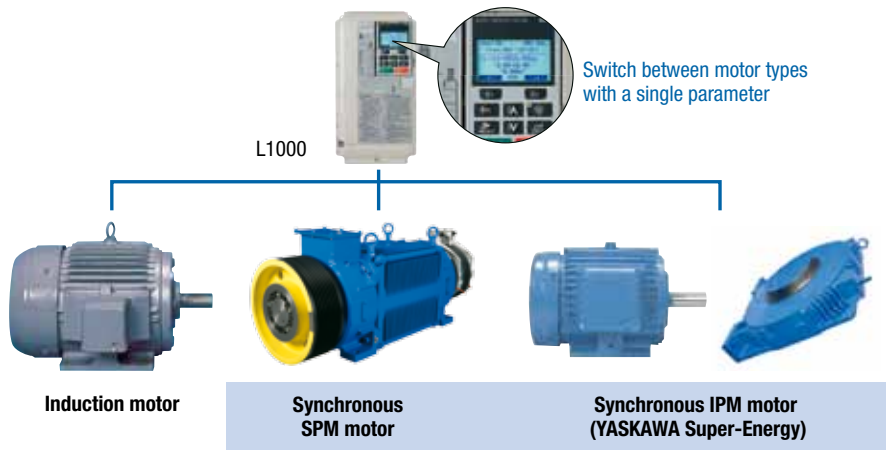

Extended inverter range with built-in braking transistor

- ▶ L1000A provides built-in braking transistor for all inverter models up to 30 kW

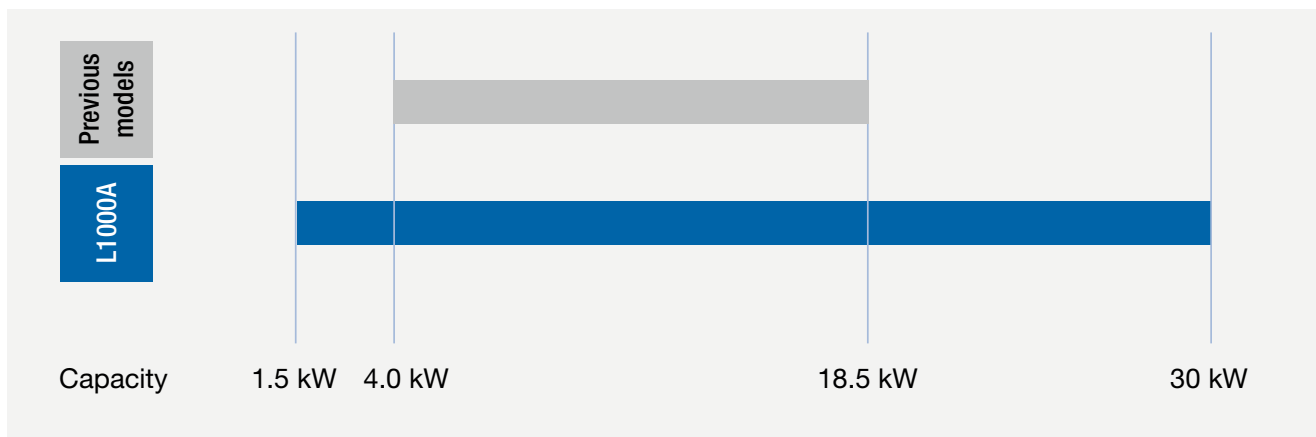



Simple Handling

Auto-Tuning options

Auto-Tuning methods optimise motor handling performance. Rotational Auto-Tuning and stationary Auto-Tuning are available for both induction motors and synchronous motors.

Auto-Tuning for induction motors

Rotational Auto-Tuning	Rotational Auto-Tuning gives most accurate results and is highly recommended. Ropes have to be removed.
Stationary Auto-Tuning 1	Automatically calculates motor parameters needed for vector control. If ropes can not be removed.
Stationary Auto-Tuning for Line-to-Line Resistance	Used for V/f Control or in vector control modes when the drive was set up properly before and the motor cable has changed.
Stationary Auto-Tuning 2	When motor test report is available. The no-load current and the rated slip must be entered from the test report, all other motor-related parameters are calculated automatically. Use if ropes can not be removed and if slip and no-load current data are available.

Auto-Tuning for PM motors

Motor Parameter Settings	Use if a motor test report is available. Input motor data like on test report. Make sure to convert data into the correct unit before if necessary.
Stationary Auto-Tuning	Use if a motor test report is not available. Input motor data like on name plate. Make sure to convert data into the correct unit before. The drive automatically calculates the additionally required motor data.
Stationary Auto-Tuning for Stator Resistance:	Tunes stator resistance only. Should be performed if the motor cable has changed.
Initial Pole Search Tuning	Judges if the rotor position can be detected without rotation or not and tunes related parameters. Should be performed after motor Auto-Tuning to decide which encoder offset tuning method is used.
Rotating Encoder Offset Tuning	Tunes the encoder offset of an absolute encoder while rotating the motor. Should be performed with no load, i. e. ropes have to be removed or car must be balanced.
Stationary Encoder Offset Tuning	Tunes the encoder offset of an absolute encoder without rotating the motor. Can only be used with an IPM motor. If offset can not be tuned properly by this method run Rotating Encoder Offset Tuning



Simple Handling

Powerful torque characteristics

Control mode	Starting torque	Speed range	Motor encoders and option cards
V/f control For modernization applications, when auto-tuning is not possible (e. g. motor current is not known)	150% at 3 Hz	1:40	-
Open-loop vector For modernization and new installations	200% at 1 Hz	1:120	-
Closed-loop vector control For geared and gearless induction motors	200% at 0 rpm	1:1500	Incremental encoders: - PG-X3 (Line driver) - PG-B3 (Complementary)
Closed-loop vector control for PM motors For geared and gearless permanent magnet motors	200% at 0 rpm	1:1500	Incremental encoders: - PG-X3 (Line driver) - PG-B3 (Complementary) Absolute encoders: - PG-F3 (Endat 2.2/22, HIPERFACE) - PG-E3 (Heidenhain ERN1387) - PG-R3 (Resolver)

USB copy unit available



- ▶ Also available: a USB copy unit as an even faster and more convenient way to back up settings and instantly program the drive.

LCD operator for simple parameter handling



All standard versions are equipped with an LCD operator including:

- ▶ 8 operating languages
- ▶ Copy function: to upload and download parameter settings instantly
- ▶ Setup Mode: prepares initial parameter to start the drive running right away
- ▶ Verify function: checks parameters which have been changed from default values



Simple Handling

Multifunction Terminal Board

- ▶ Terminal board with a Parameter Backup Function
The terminal board's ability to save parameter setting data makes it easy to get the application back online in the event of a failure requiring drive replacement.



Parameter		
Name	Number	Setting
ND/HD	C6-01	1
Control Mode	A1-02	0
Frequency Reference Selection	b1-01	1
Run Command Selection	b1-02	1

DriveWizard Plus

Engineering tool DriveWizard Plus

- ▶ To adjust and edit parameters, access all monitors, create customized operation sequences, and observe drive performance with the oscilloscope function
- ▶ Drive Replacement feature in DriveWizard Plus: automatically converts previous product parameter values to L1000A parameters, saving valuable time during equipment replacement and application upgrading
- ▶ The inverter drive is equipped with a USB port for connecting to a PC

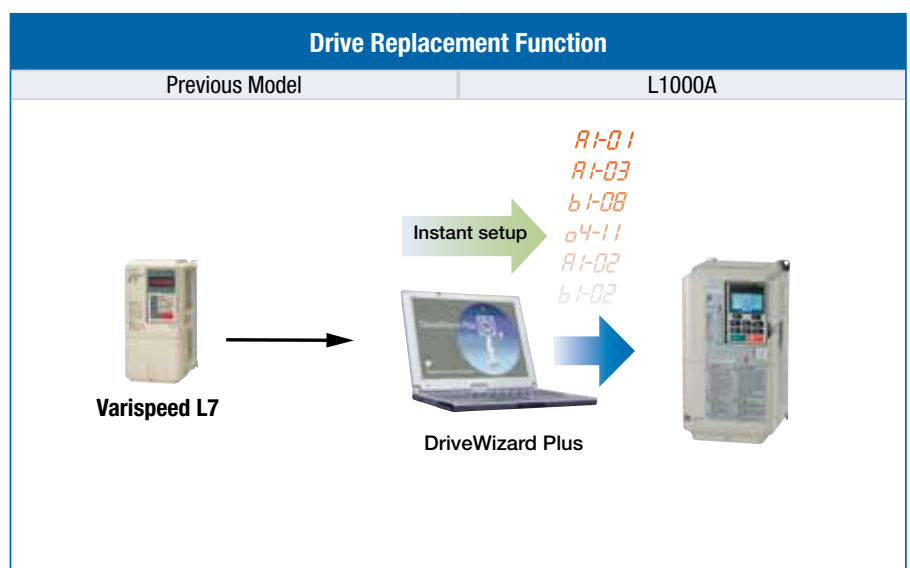

Note: To obtain a copy of DriveWizard Plus, contact a YASKAWA representative.



Safe & Comfortable Rides

Torque compensation at start without load sensor

New sensor-less torque compensation function includes the YASKAWA advanced anti-rollback function*, preventing shock at start to ensure a smooth start

*Anti-rollback function: provides the right amount of torque compensation to suppress shock and prevent speed variations when the brake is released.

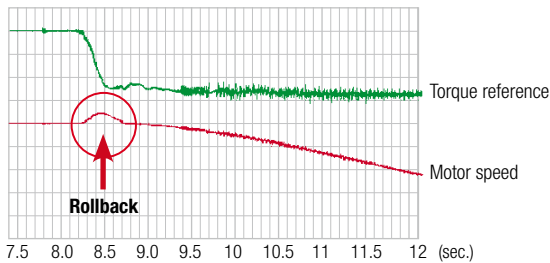

Zero servo gain 2 (S3-02) **Before adjustment**

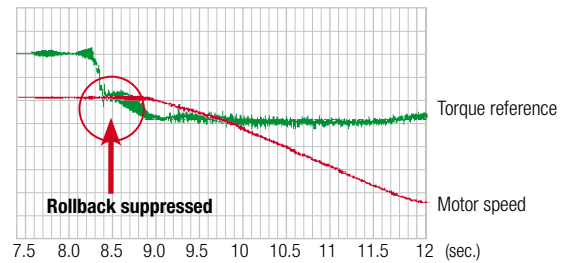

Zero servo gain 2 (S3-02) **After adjustment**

Improved torque ripple suppression

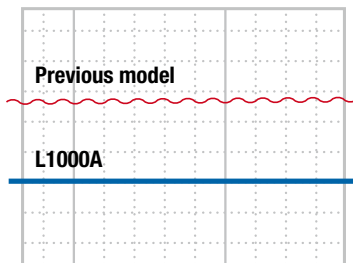

Torque ripple comparison
(closed-loop vector at 0 speed)

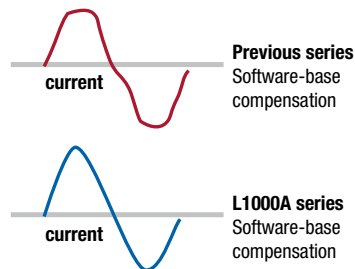

On-Delay compensation function nASIC

- ▶ Smooth start/stop due to optimised torque ripple suppression.
- ▶ Precise motor torque performance for comfortable acceleration and deceleration characteristics

Overshoot and anti-vibration control

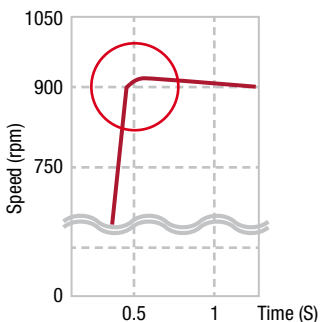

Previous speed control

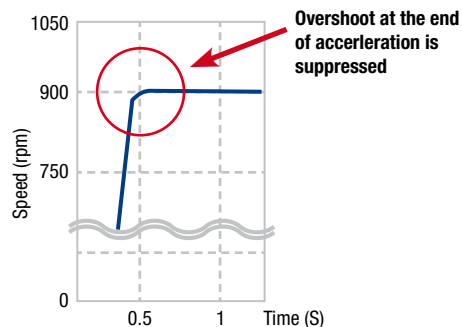

With Feed Forward control

- ▶ Feed forward function allows ideal speed response.
- ▶ Acceleration and deceleration compensation prevent vibration and overshoot.
- ▶ Adjustment of S-curve settings for acceleration and deceleration to ensure a perfectly smooth ride.



Safe & Comfortable Rides

UPS and light-load direction search function for rescue operation

- ▶ A single-phase 230 V UPS or 48 – 96 VDC battery (24 V control power supply) provides the inverter drive with the necessary power for evacuation.
- ▶ In case of power failure the L1000A can bring the cabin to the next floor for evacuation using the UPS.
- ▶ A “light-load direction search” function triggered by the controller detects the light direction of the lift.



UPS wiring and operation

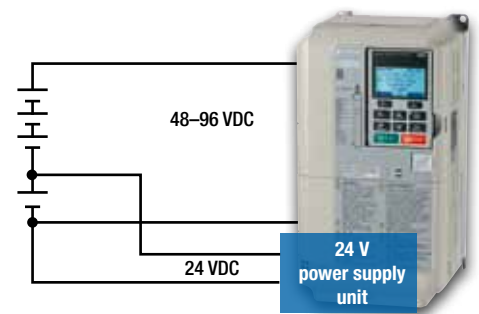

Back-up battery wiring and operation

*For clarity, the illustrations have been simplified, omitting several switches and control signals.

Long lifetime design

- ▶ Designed for 10 years of maintenance-free operation

IGBTs are designed 3 million full load starts.

Cooling fan and capacitors have been carefully selected for a lift life of at least 70.000 hrs of maintenance free operation.

- ▶ Performance life monitor

The L1000A is equipped with performance life monitors that notify the user of part wear and maintenance periods to prevent problems before they occur.

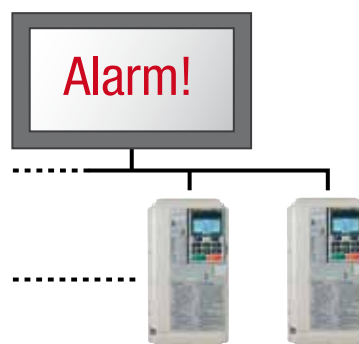

Operator Display	Corresponding Component
LT-1	Cooling fan
LT-2	Capacitors
LT-3	Inrush prevention relay
LT-4	IGBTs

Alarm signals can be transmitted to a PLC or control device.

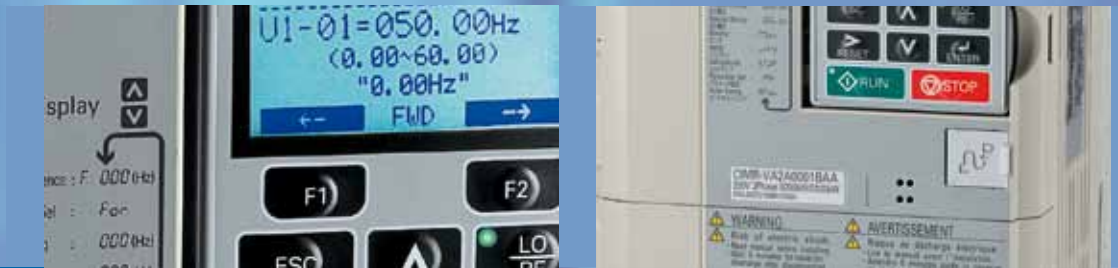

Safe & Comfortable Rides

Safety features as standard functions

- ▶ One contactor solution according to EN81-1*
- ▶ L1000A is approved for being implemented to system design according to EN954-1 Cat. 3, stop category 0, ISO EN13849-1 PLd and IEC EN 61508 SIL2.
- ▶ An External Device Monitor (EDM) function has also been added to monitor the safety status of the drive.

* Under Development

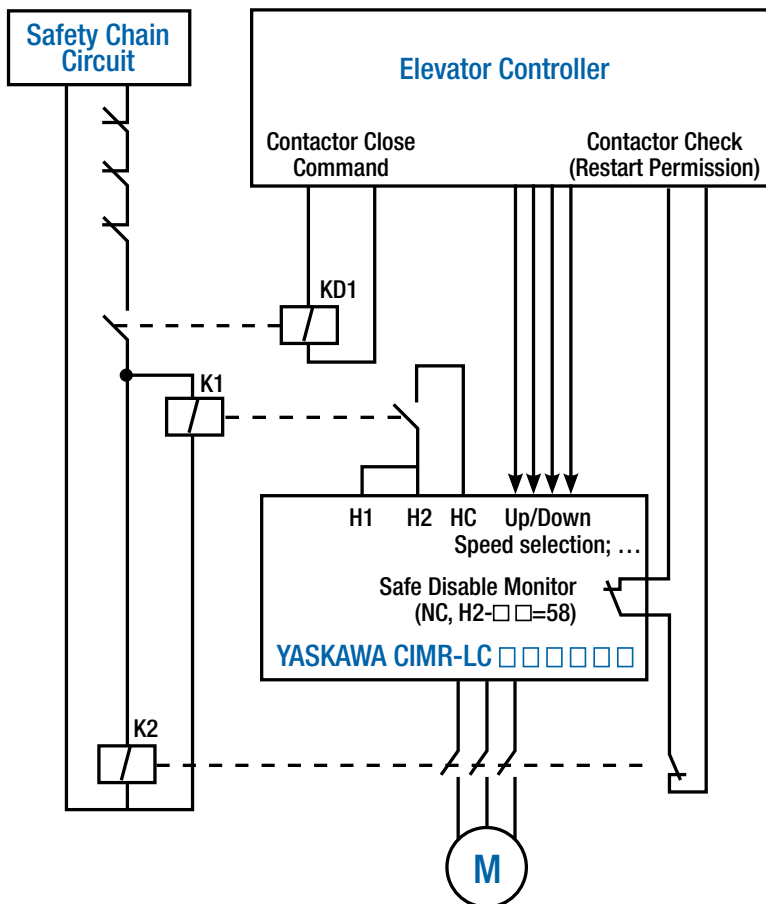



Standard Specifications

	Item	Specifications
Control Characteristics	Control Method	V/f Control, Open Loop Vector Control, Closed Loop Vector Control, Closed Loop Vector for PM
	Frequency Control Range	0.01 to 120 Hz
	Frequency Accuracy (Temperature Fluctuation)	Digital reference: within $\pm 0.01\%$ of the max. output frequency (-10 to $+40^{\circ}\text{C}$) Analog reference: within $\pm 0.1\%$ of the max. output frequency ($25^{\circ}\text{C} \pm 10^{\circ}\text{C}$)
	Frequency Setting Resolution	Digital reference: 0.01 Hz Analog reference: 0.03 Hz / 60 Hz (11 bit)
	Output Frequency Resolution	0.001 Hz
	Frequency Setting Signal	-10 to +10 V, 0 to +10 V
	Starting Torque	150%/3 Hz (V/f Control), 200%/0.3 Hz* ¹ (Open Loop Vector Control), 200%/0 r/min ⁻¹ (Closed Loop Vector Control, Closed Loop Vector Control for PM)
	Speed Control Range	1:1500 (Closed Loop Vector Control and Closed Loop Vector for PM) 1:200 (Open Loop Vector Control) 1:40 (V/f Control)
	Speed Control Accuracy	$\pm 0.2\%$ in Open Loop Vector Control ($25^{\circ}\text{C} \pm 10^{\circ}\text{C}$) * ² , $\pm 0.02\%$ in Closed Loop Vector Control ($25^{\circ}\text{C} \pm 10^{\circ}\text{C}$)
	Speed Response	10 Hz in Open Loop Vector ($25^{\circ}\text{C} \pm 10^{\circ}\text{C}$), 50 Hz in Closed Loop Vector Control ($25^{\circ}\text{C} \pm 10^{\circ}\text{C}$) (excludes temperature fluctuation when performing Rotational Auto-Tuning)
	Torque Limit	All Vector Control allows separate settings in four quadrants (available in OLV, CLV, CLV/PM)
	Accel/Decel Time	0.00 to 600.00 s (4 selectable combinations of independent acceleration and deceleration settings)
	Braking Torque	Drives of 200/400 V 30 kW or less have a built-in braking transistor.
	V/f Characteristics	Freely programmable
Main Control Functions	Inertia Compensation, Position Lock at Start and Stop/Anti-Rollback Function, Overtorque/Undertorque Detection, Torque Limit, Speed Reference, Accel/decel Switch, 5 Zone Jerk Settings, Auto-tuning (Stationary and Rotational Motor/Encoder Offset Tuning), Dwell, Cooling Fan on/off Switch, Slip Compensation, Torque Compensation, DC Injection Braking at Start and Stop, MEMOBUS/Modbus Comm. (RS-422/485 max, 115.2 kbps), Fault Restart, Removable Terminal Block with Parameter Backup Function, Online Tuning, High Frequency Injection, Short Floor, Rescue Operation(Light Load Direction Search Function), Inspection Run, Brake Sequence, Speed related parameters with elevator units display, etc.	
Protection Function	Motor Protection	Motor overheat protection based on output current
	Momentary Overcurrent Protection	Drive stops when output current exceeds 200%
	Overload Protection	Drive stops after 60 s at 150% (acceleration current 175%) of rated output current* ³
	Overvoltage Protection	200 V class: Stops when DC bus exceeds approx. 410 V, 400 V class: Stops when DC bus exceeds approx. 820 V
	Undervoltage Protection	200 V class: Stops when DC bus exceeds approx. 190 V, 400 V class: Stops when DC bus exceeds approx. 380 V
	Heatsink Overheat Protection	Thermistor
	Stall Prevention	Stall prevention during acceleration/deceleration and constant speed operation
	Ground Fault Protection	Protection by electronic circuit* ⁴
Charge LED	Charge LED remains lit until DC bus has fallen below approx. 50 V	
Operating Environment	Area of Use	Indoors
	Ambient Temperature	-10 to $+50^{\circ}\text{C}$ (open chassis), -10 to $+40^{\circ}\text{C}$ (NEMA Type 1)
	Humidity	95% RH or less (no condensation)
	Storage Temperature	-20 to $+60^{\circ}\text{C}$ (short-term temperature during transportation)
	Altitude	Up to 1000 meters (output derating of 1% per 100 m above 1000 m, max. 3000 m)
Shock	10 Hz to 20 Hz, 9.8 m/s ² max. 20 Hz to 55 Hz, 5.9 m/s ² (200 V: 45 kW or more, 400 V: 55 kW or more) or 2.0 m/s ² max. (200 V: 55 kW or less, 400 V: 75 kW or less)	
Safety Standard	EN954-1 safe category 3 stop category 0; EN ISO 13849-1; IEC EN 61508 SiL2	
Protection Design	IP20	

*1: Requires a drive with recommended capacity.

*2: Speed control accuracy may vary slightly depending on installation conditions or motor used. Contact Yaskawa for details.

*3: Overload protection may be triggered when operating with 150% of the rated output current if the output frequency is less than 6 Hz.

*4: Protection may not be provided under the following conditions as the motor windings are grounded internally during run:

• Low resistance to ground from the motor cable or terminal block. • Drive already has a short-circuit when the power is turned on.

Connection Diagram

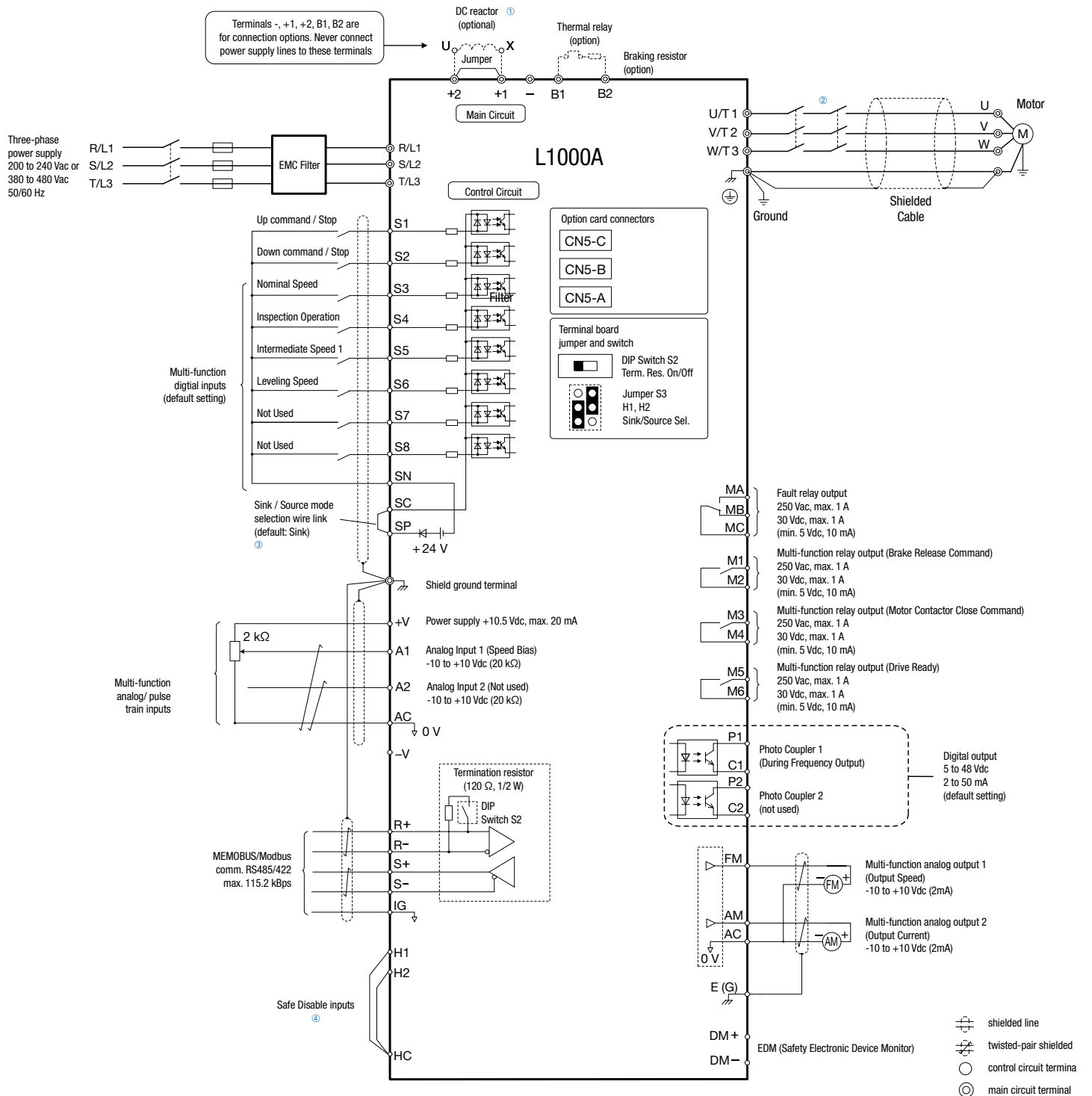

① Remove the jumper when installing a DC reactor. Models CIMR-LC2A0085 through 0115 and 4A0045 through 0150 come with a built-in DC reactor.

② The drive provides a stop function in compliance with Stop Category 0 (EN60204-1) and "Safe Torque Off" (IEC61800-5-2). It has been designed to meet the requirements of the EN954-1/ISO13849-1, Category 3 and IEC61508, SIL2. Using this function the number of motor contactors can be reduced to one.

③ Never short terminals SP and SN, as doing so will damage the drive.

④ Disconnect the wire jumper between H1 - HC and H2 - HC when utilizing the Safe Disable inputs.

Note: 1. The drive should be implemented in the system in a way so that a drive fault causes the safety chain to open. Always use terminal MA-MB-MC for this purpose.

2. Even though no fault is present conditions where the drive can not start can occur, e.g. when the Digital Operator is left in the Programming Mode. Use the "Drive Ready" output (default set to terminals M5-M6) to interlock operation in such situations.

Dimensions

Enclosures

Enclosures of standard products vary depending on the model. Refer to the table below.

Voltage class	200 V														400 V																	
	CIMR-LC2A														CIMR-LC4A																	
Model	0008	0011	0018	0025	0033	0047	0060	0075	0085	0115	0145	0180	0215	0283	0364	0415	0005	0006	0009	0015	0018	0024	0031	0039	0045	0060	0075	0091	0112	0150	0180	0216
Max. Applicable Motor Capacity [kW]	1.5	2.2	4.0	5.5	7.5	11	15	18.5	22	30	37	45	55	75	90	110	1.5	2.2	4.0	5.5	7.5	11	15	18.5	22	30	37	45	55	75	90	110
IP20	Standard							Note*							Standard on request							Note*										

Note*: with reduced bending space

IP20 (with reduced bending space)

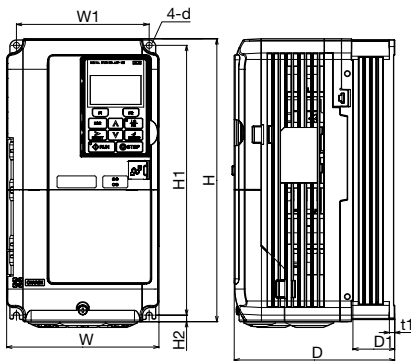

Fig. 1

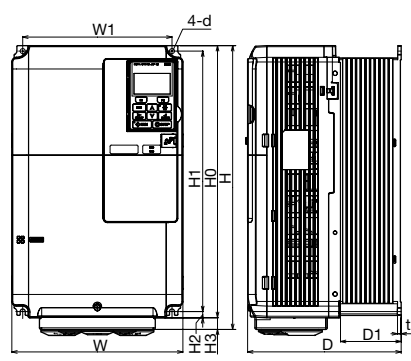

Fig. 2

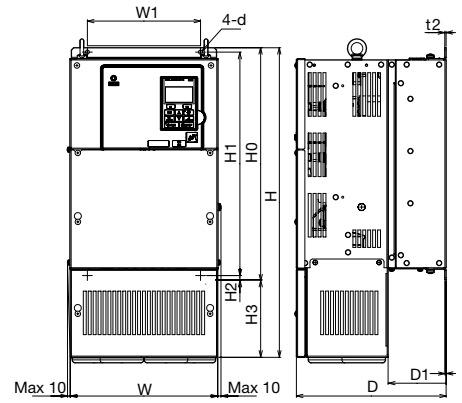

Fig. 3

200 V Class

Model CIMR-LC2A □□□□	Max. applicable motor capacity [kW]	Figure	Dimensions in mm												Weight (kg)	
			W	H	D	W1	H0	H1	H2	H3	D1	t1	t2	d		
0008	1.5	Fig. 1	140	260	147	122	-	248	6	-	38	5	-	M5	3.2	
0011	2.2				164										3.5	
0018	4.0				167										4.0	
0025	5.5				167										4.0	
0047	11	Fig. 2	180	300	187	160	-	284	8	-	75	-	-	M5	5.6	
0060	15				192										8.7	
0075	18.5				192										9.7	
0085	22				192										9.7	
0115	30	Fig. 3	254	534	258	195	400	385	-	134	100	2.3	2.3	M6	23	
0145	37														220	28
0180	45														279	28
0215	55														279	28
0283	75	Fig. 3	329	630	283	260	550	535	7.5	80	110	-	-	M6	40	
0346	90														260	81
0415	110														260	86
															260	105
		Fig. 3	450	705	330	325	705	680	12.5	163	130	3.2	3.2	M10	81	
															325	86
															325	86
															325	86
		Fig. 3	500	800	350	370	800	773	13	238	130	4.5	4.5	M12	105	

400 V Class

Model CIMR-LC4A □□□□	Max. applicable motor capacity [kW]	Figure	Dimensions in mm												Weight (kg)	
			W	H	D	W1	H0	H1	H2	H3	D1	t1	t2	d		
0005	1.5	Fig. 1	140	260	147	122	-	248	6	-	38	5	-	M5	3.2	
0006	2.2				164										3.4	
0009	4.0				164										3.5	
0015	5.5				164										3.5	
0018	7.5	Fig. 1	180	300	167	160	-	284	8	-	75	-	-	M5	3.9	
0024	11				167										5.4	
0031	15				167										5.7	
0039	18.5				167										5.7	
0045	22	Fig. 3	220	350	197	192	400	385	-	65	100	-	-	M6	8.3	
0060	30														192	23
0075	37														192	27
0091	45														192	27
0112	55	Fig. 3	279	515	258	220	450	435	7.5	120	105	2.3	-	M6	39	
0150	75														220	43
0180	90														220	45
0216	110														220	45
		Fig. 3	329	630	258	260	510	495	7.5	180	110	-	-	M6	43	
															260	45
															260	85
															260	85
		Fig. 3	450	705	330	325	705	680	12.5	163	130	3.2	3.2	M10	85	
															325	85
															325	85
															325	85
		Fig. 3	500	800	350	370	800	773	13	236	130	4.5	4.5	M12	103	



Options

Name	Purpose	Model
AC Chokes	Reducing Harmonics	For detailed information contact YASKAWA.
Analog input	Enables high-precision and high-resolution analog speed reference setting. <ul style="list-style-type: none"> Input signal level: -10 to +10 Vdc (20 kΩ) 4 to 20 mA (500 Ω) Input channels: 3 channels, DIP switch for input voltage/input current selection Input resolution: Input voltage 13 bit signed (1/8192) Input current 1/6554 	AI-A3
Digital Input	Enables 16-bit digital speed reference setting. <ul style="list-style-type: none"> Input signal: 16 bit binary, 2 digit BCD + sign signal + set signal Input voltage: +24 V (isolated) Input current: 8 mA Selectable Parameter: 8 bit, 12 bit, 16 bit 	DI-A3
CANopen communications interface	Used for running or stopping the drive, setting or referencing parameters and monitoring output frequency, output current, or similar items through CANopen communication with the host controller.	SI-S3
Analog monitor	Outputs analog signal for monitoring drive output state (output freq., output current etc.) <ul style="list-style-type: none"> Output resolution: 11 bit signed (1/2048) Output voltage: -10 to +10 Vdc (non-isolated) Output channels: 2 channels 	A0-A3
Digital output	Outputs isolated type digital signal for monitoring drive run state (alarm signal, zero speed detection, etc.). Output channel: Photo coupler 6 channels (48 V, 50 mA or less) Relay contact output 2 channels 250 Vac, 1 A or less 30 Vdc, 1 A or less	DO-A3
Open collector PG interface	For control modes requiring a PG encoder for motor feedback. <ul style="list-style-type: none"> Phase A, B, and Z pulse (3-phase) inputs (complementary type) PG frequency range: Approx. 50 kHz max. Power supply output for PG: +24 V, max. current 30 mA Pulse monitor output: Open collector, +24 V, max. current 30 mA Power supply output for PG: +12 V, max. current 200 mA 	PG-B3
Line Driver PG interface	For control modes requiring a PG encoder for motor feedback. <ul style="list-style-type: none"> Phase A, B, and Z pulse (differential pulse) inputs (RS-422) PG frequency range: up to 300 kHz (approx.) Pulse monitor output: RS-422 Power supply output for PG: +5 V or +12 V, max. current 200 mA 	PG-X3
Absolute encoder	Endat Motor Feedback	PG-F3 (Endat. 2.2/22, HIPERFACE)
Absolute encoder	Heidenhain Motor Feedback	PG-E3 (Heidenhain ERN1387)
Absolute encoder	Resolver Motor Feedback	PPG-R3 (Resolver)*
LED Operator	Easy long distance reading	JVOP-182
Braking Resistor	Used to shorten the deceleration time by dissipating regenerative energy	For detailed information contact YASKAWA.
Braking Chopper Unit	Shortened deceleration time results when used with a Braking Resistor Unit. For units above 30 kW	CDBR series
24 V Power Supply	Provides power supply for the control circuit and option boards. Note: Parameter settings cannot be changed when the drive is operating solely from this power supply.	200 V Class: PS-A10LB 400 V Class: PS-A10HB
USB Copy Unit (RJ-45/USB compatible plug)	<ul style="list-style-type: none"> Adapter for connecting the drive to the USB port of a PC Can copy parameter settings easily and quickly to be later transferred to another drive. 	JVOP-181
LCD operator extension cable	Cable for connecting the LCD operator.	WV001: 1 m WV003: 3 m

*coming soon

Note: contact the manufacturer in question for availability and specifications of non-YASKAWA products.

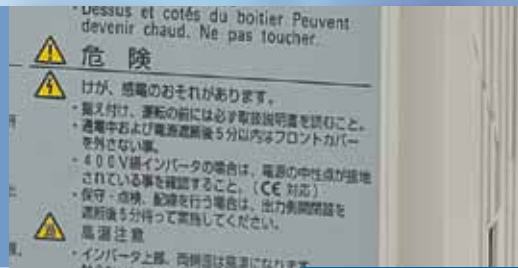

Options

Name	Purpose	Model		
Input noise filter	Reduces noise from the line that enters into the drive input power system. Should be installed as close as possible to the drive.	Three-phase 400 V	Filter:	Footmounted:
		CIMR-LC4A0005xAA	FB-40008A	yes
		CIMR-LC4A0006xAA	FB-40008A	yes
		CIMR-LC4A0009xAA	FB-40014A	yes
		CIMR-LC4A0015xAA	FB-40025A	yes
		CIMR-LC4A0018xAA	FB-40025A	yes
		CIMR-LC4A0024xAA	FB-40044A	yes
		CIMR-LC4A0031xAA	FB-40044A	yes
		CIMR-LC4A0039xAA	FB-40060A	no
		CIMR-LC4A0045xAA	FB-40060A	no
		CIMR-LC4A0060xAA	FB-40072A	no
		CIMR-LC4A0075xAA	FB-40105A	no
		CIMR-LC4A0091xAA	FB-40105A	no
		CIMR-LC4A0112xAA	FB-40170A	no
		CIMR-LC4A0150xAA	FB-40170A	no
		CIMR-LC4A0180xAA	FB-40250A	no
CIMR-LC4A0216xAA	FB-40250A	no		
AC Reactors	Used for harmonic current suppression and total improving power factor. Should be used if the power supply capacity is larger than 600 kVA. - Suppresses harmonic current - Improves the power factor of the input power supply	400V	AC Reactor IP00	AC Reactor IP20
		CIMR-LC4A0005xAA	under development	under development
		CIMR-LC4A0006xAA	under development	under development
		CIMR-LC4A0009xAA	B0903084	B0903088
		CIMR-LC4A0015xAA	B0903085	B0903089
		CIMR-LC4A0018xAA	B0903085	B0903089
		CIMR-LC4A0024xAA	B0903086	B0903090
		CIMR-LC4A0031xAA	B0903087	B0903091
		CIMR-LC4A0039xAA	B0910009	B0910014
		CIMR-LC4A0045xAA	B0910009	B0910014
		CIMR-LC4A0060xAA	B0910011	B0910016
		CIMR-LC4A0075xAA	B0910011	B0910016
		CIMR-LC4A0091xAA	B0910013	B0910018
		CIMR-LC4A0112xAA	B0910013	B0910018
		CIMR-LC4A0150xAA	under development	under development
		CIMR-LC4A0180xAA	under development	under development
CIMR-LC4A0216xAA	under development	under development		

Model Number Key

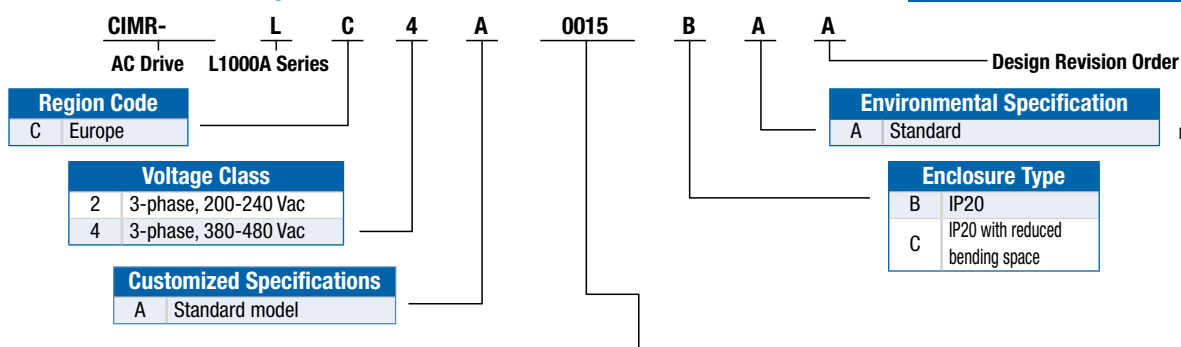

Note: Contact YASKAWA for more information on environmental tolerance specifications.

Ratings & Type Descriptions

200 V			400 V		
Model	Rated output current [A]	Max. applicable motor*3 [kW]	Model	Rated output current [A]	Max. applicable motor*3 [kW]
0008	8*1	1.5	0005	4.8*1	1.5
0011	11*1	2.2	0006	5.5*1	2.2
0018	18*1	4.0	0009	9.2*1	4.0
0025	25*1	5.5	0015	14.8*1	5.5
0033	33*1	7.5	0018	18*1	7.5
0047	47*1	11	0024	24*1	11
0060	60*1	15	0031	31*1	15
0075	75*1	18.5	0039	39*1	18.5
0085	85*1	22	0045	45*1	22
0115	115*1	30	0060	60*1	30
0145	145*2	37	0075	75*5	37
0180	180*2	45	0091	91*1	45
0215	215*2	55	0112	112*2	55
0283	283*2	75	0150	150*2	75
0346	346*2	90	0180	180*2	90
0415	415*2	110	0216	216*2	110

*1: This value assumes a maximum carrier frequency of 8 kHz. Increasing the carrier frequency requires a reduction in current.

*2: This value assumes a maximum carrier frequency of 5 kHz. Increasing the carrier frequency requires a reduction in current.

*3: The motor capacity (kW) refers to a Yaskawa 4-pole, 60 Hz, 200 V motor or 400 V motor. The rated output current of the drive output amps should be equal to or greater than the motor rated current.



YASKAWA Europe GmbH

Drives & Motion Division
Hauptstr. 185
65760 Eschborn
Germany

Tel.: +49 6196 569-300
Tel.: +49 6196 569-398
info@yaskawa.eu.com
www.yaskawa.eu.com